



cima

CENTRO DE INVESTIGACIÓN MÉDICA APLICADA
UNIVERSIDAD DE NAVARRA

Therapeutic activity of the combination of anti-CD137, OX40 and B7-H1 on a spontaneous mouse model of hepatocarcinoma

Aizea Morales-Kastresana

SITC 28th Annual Meeting, November 10th 2013

amoralesc@unav.es

No potential conflict of interests

Activating signals: TNFRSF members CD137 and OX40

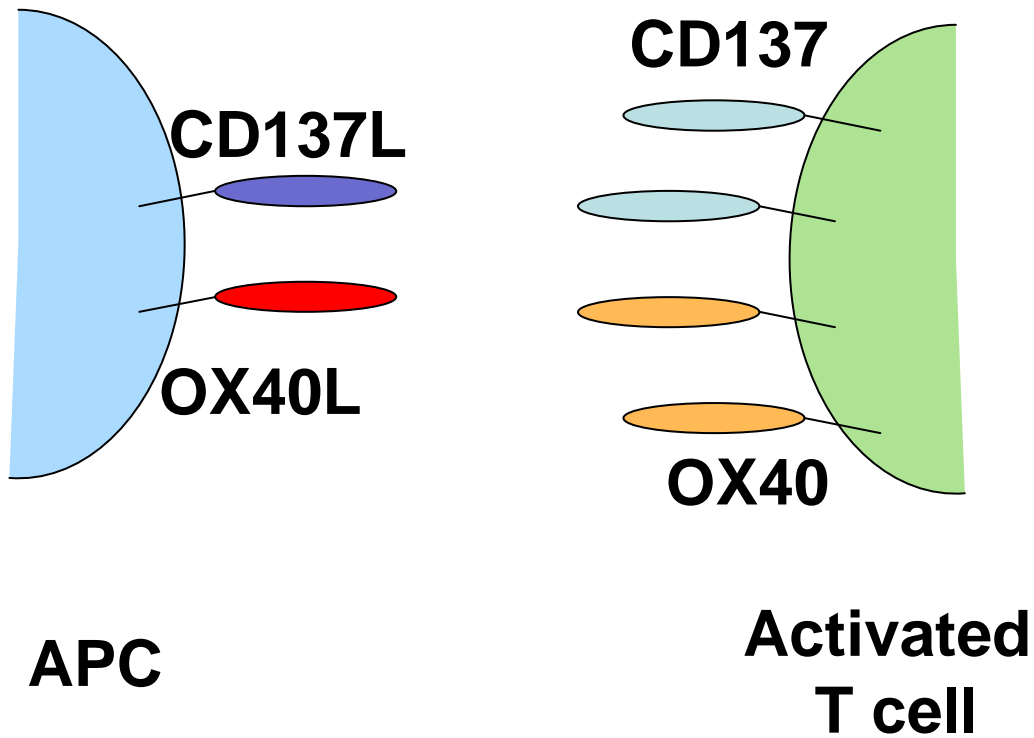

Activating signals: TNFRSF members CD137 and OX40

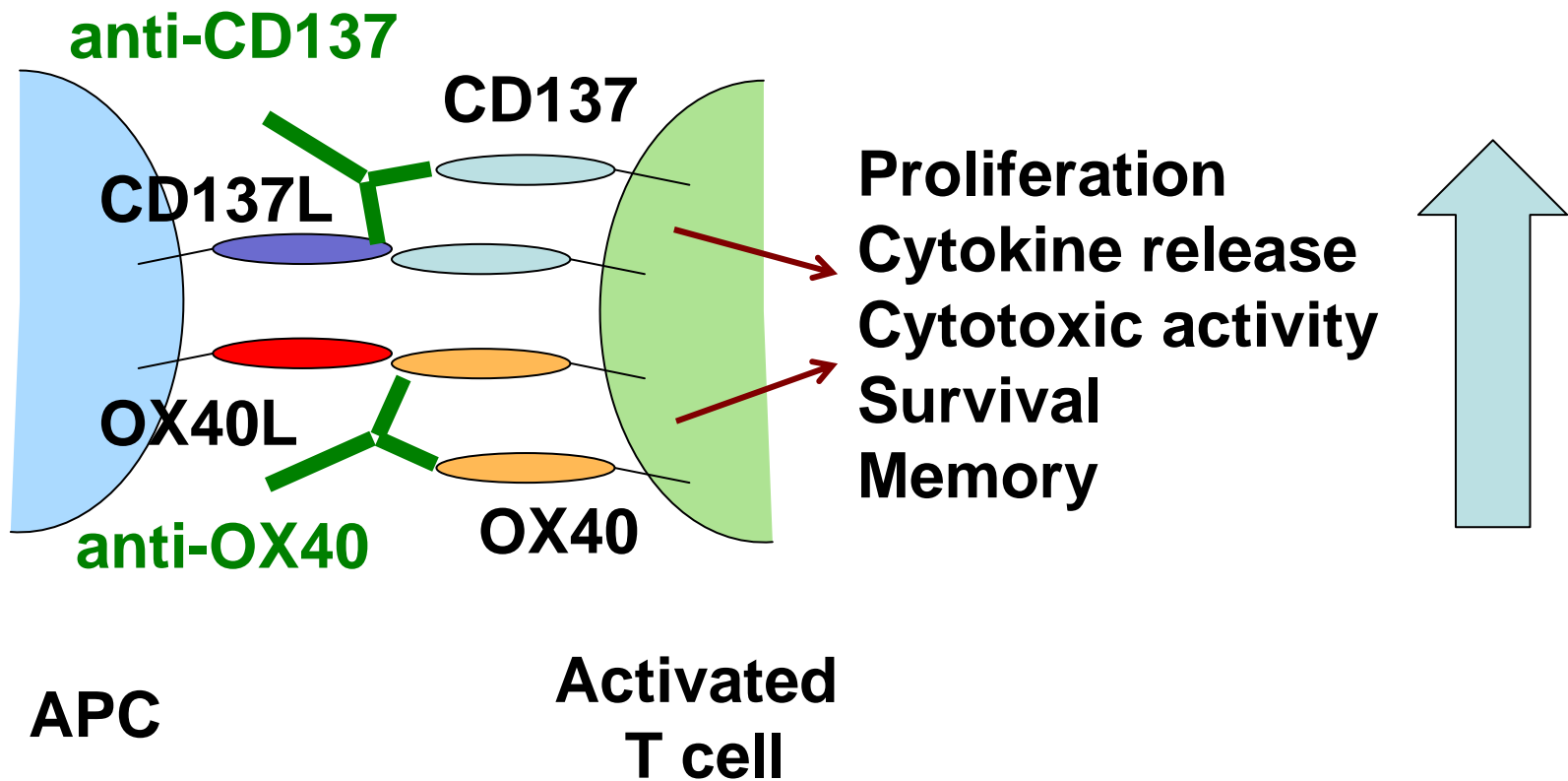

Inhibitory signals

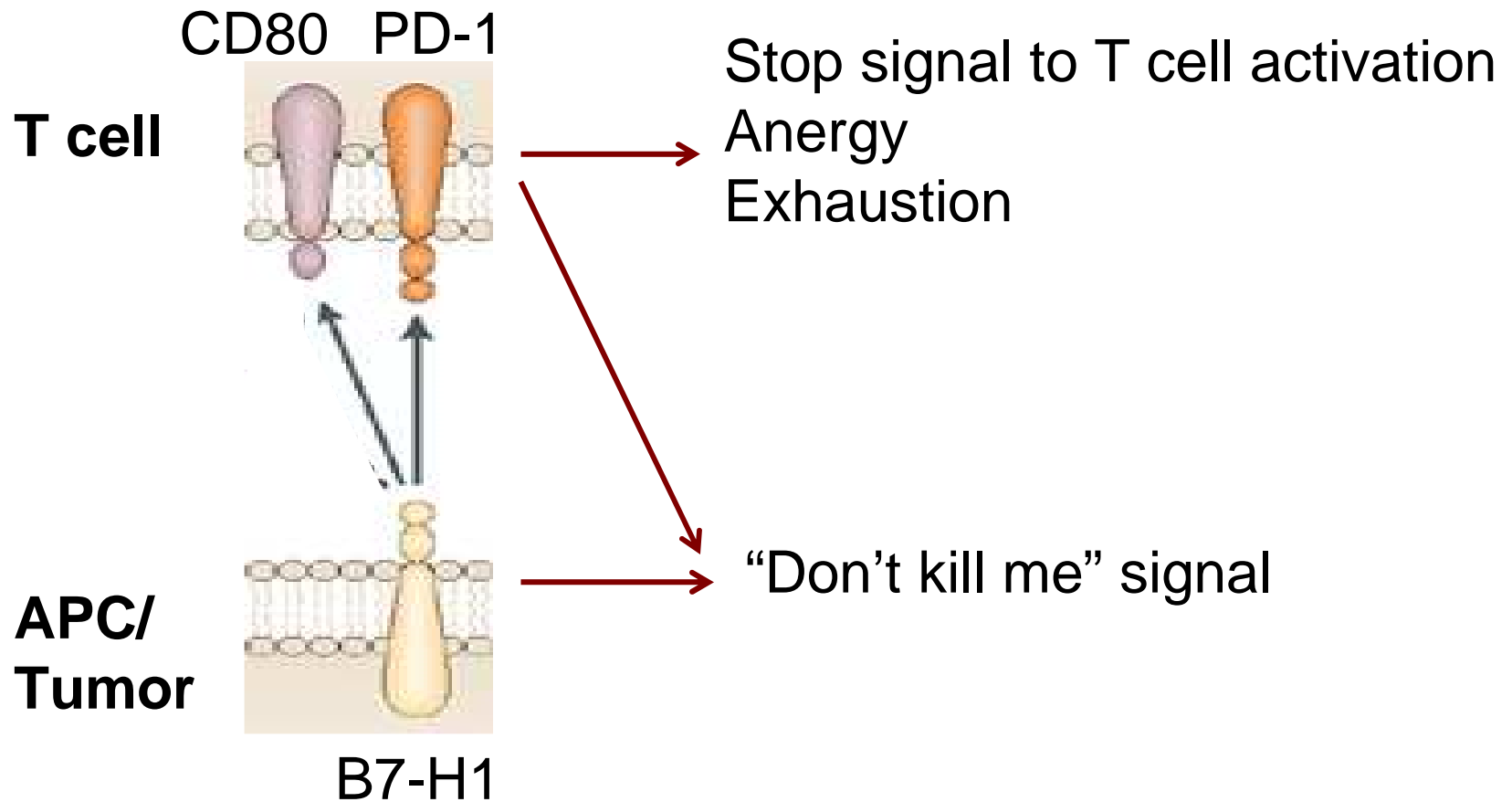

Inhibitory signals

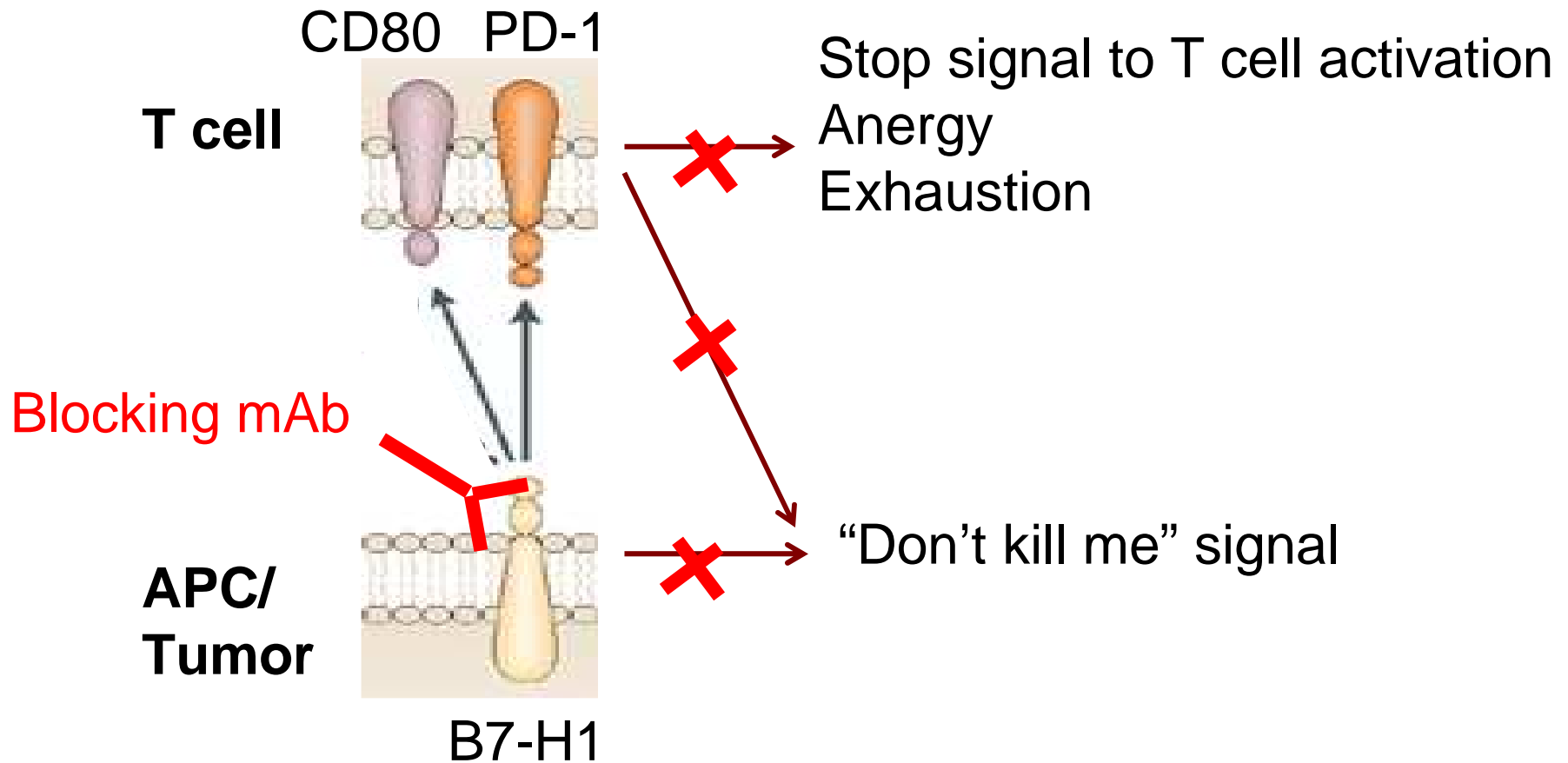

Combo3

anti-CD137
anti-OX40
anti-B7-H1

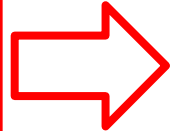

Transgenic mouse model of spontaneous hepatocarcinoma (c-myc-OVA tg+)

Inducible generation of HCC: Tet-off system

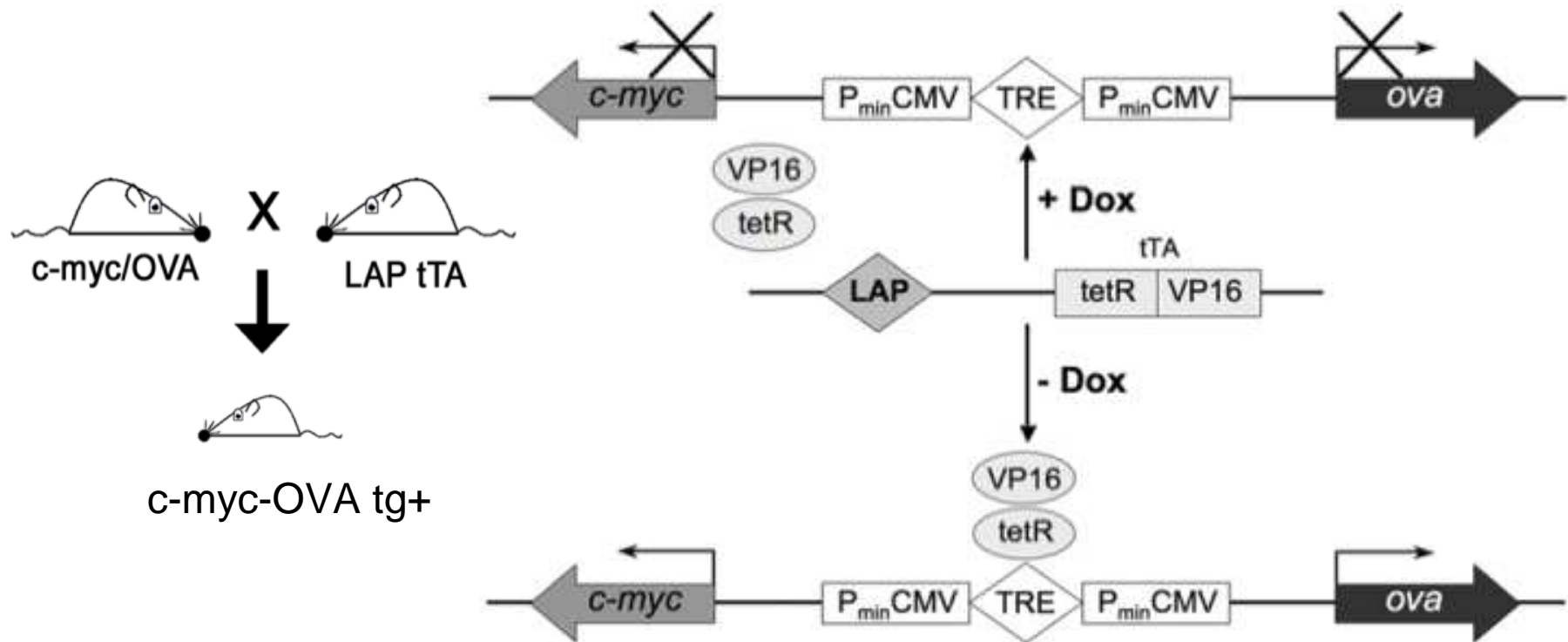

Doxycycline



Breeding

Birth

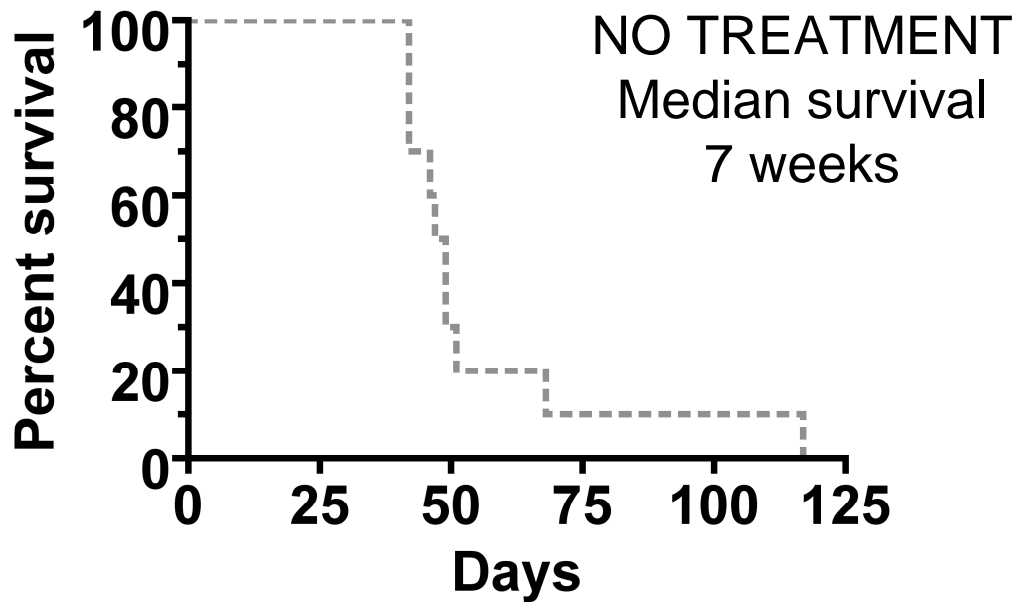

Littermate

c-myc-OVA tg+

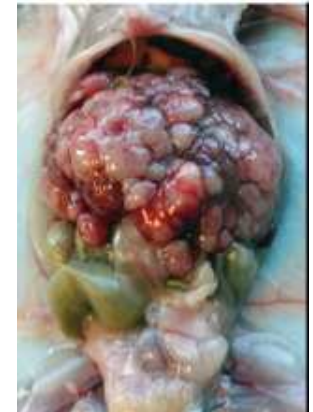

Ney et al. Hepatology 2009

Targets for anti-CD137, anti-OX40 and anti-B7-H1 are expressed on TILs

TILs in
3-week old
c-myc OVA tg+
mice

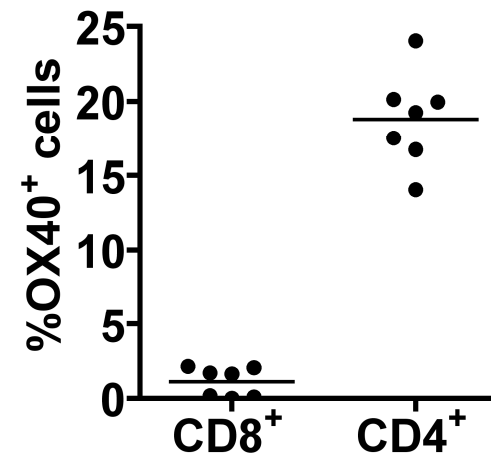
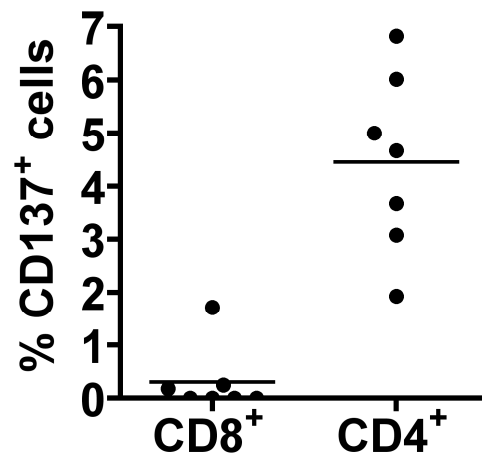
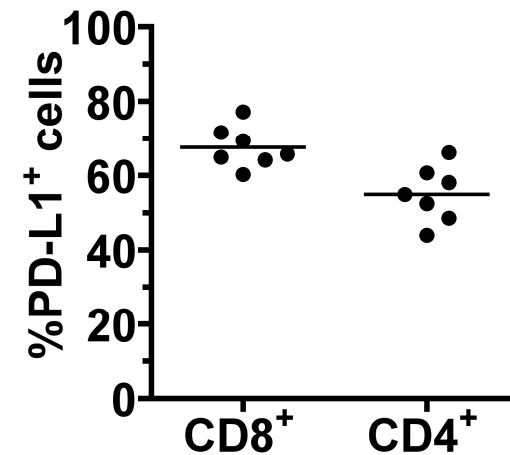
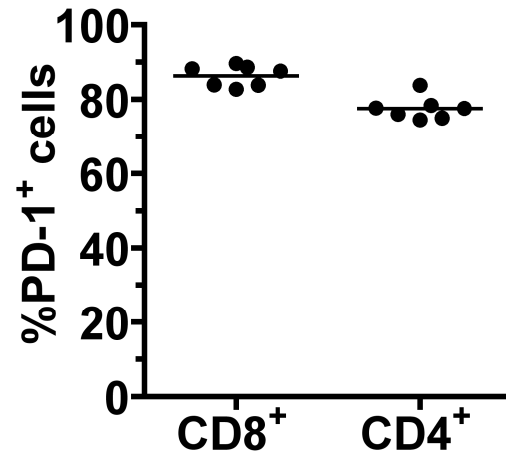

IMMUNOTHERAPY with mAbs + ACT

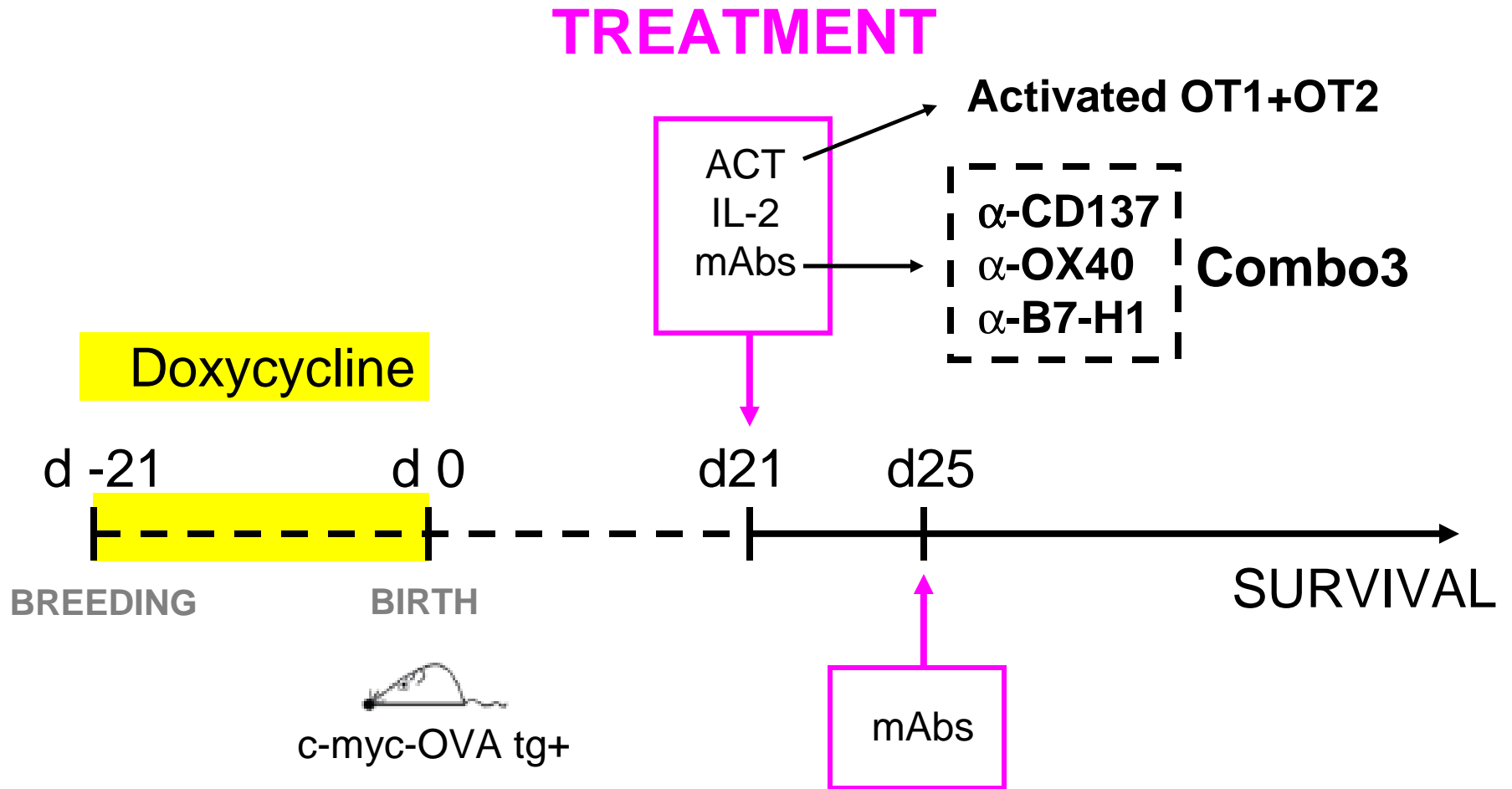

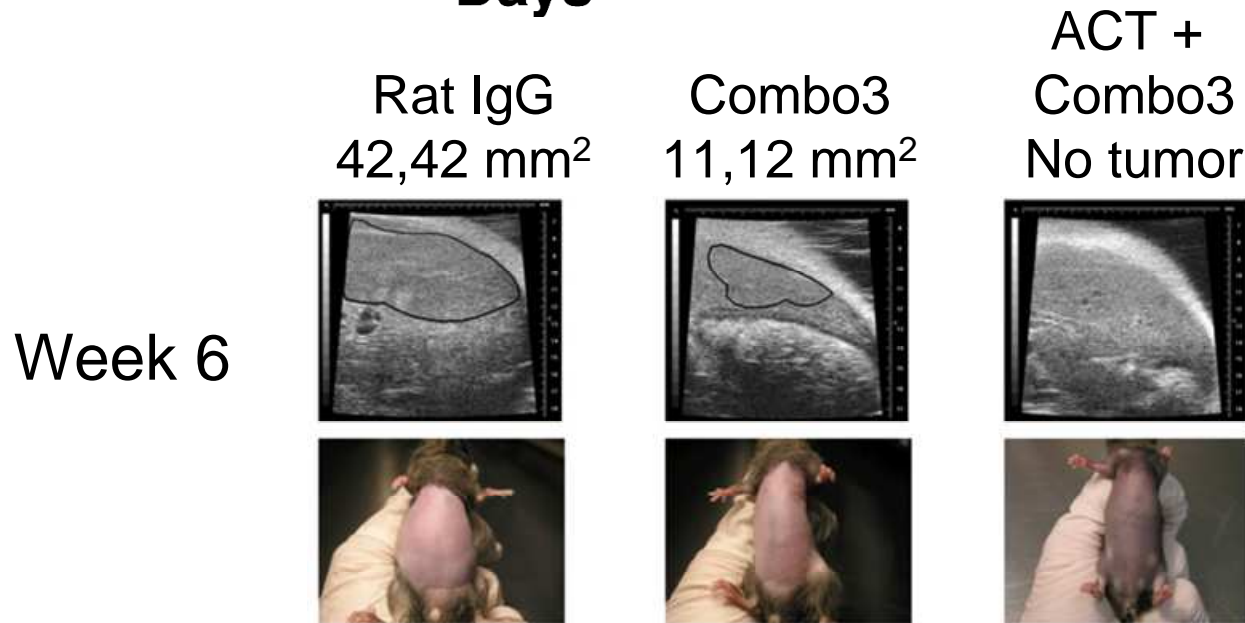
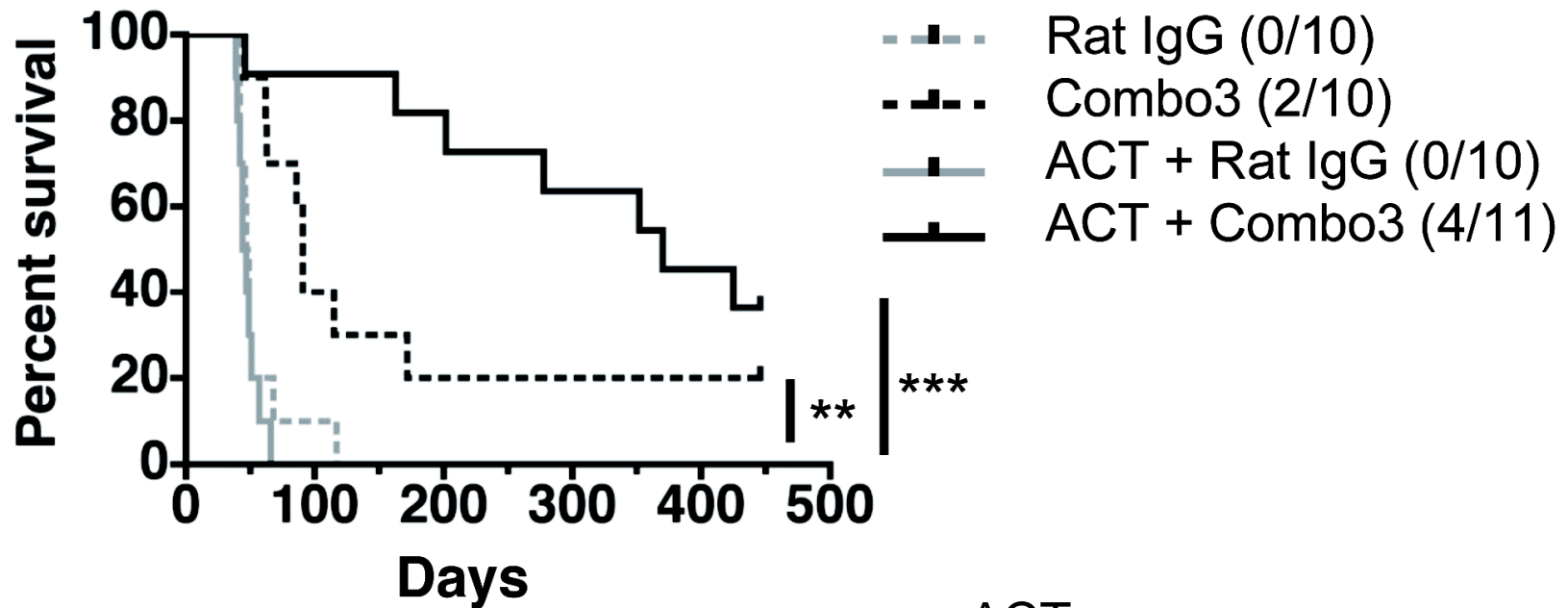

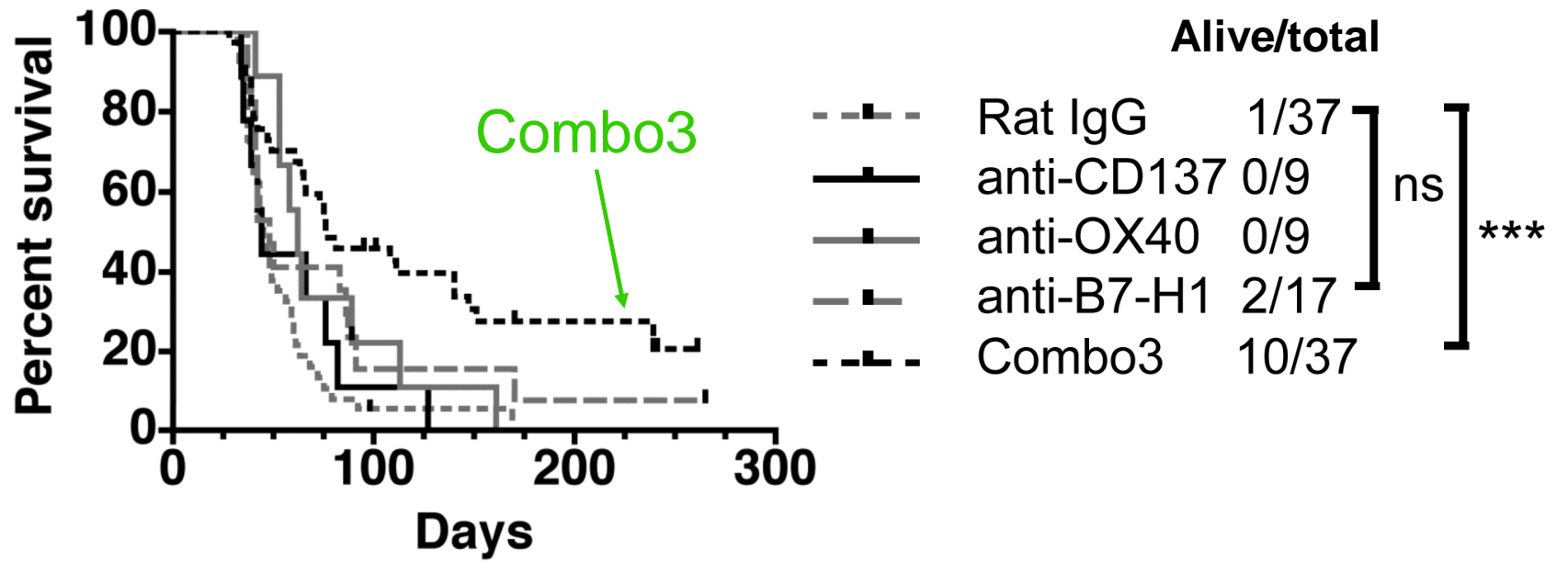

Increased T cell infiltrates upon Combo3 treatment

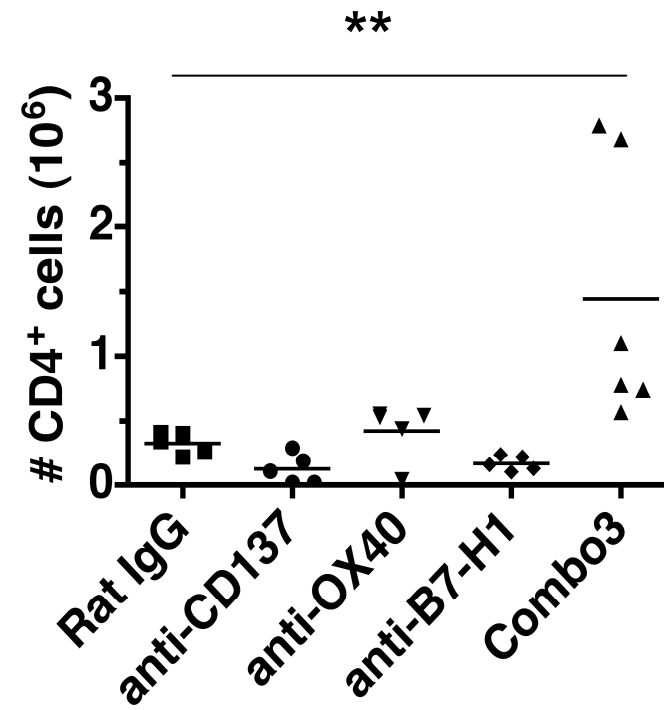
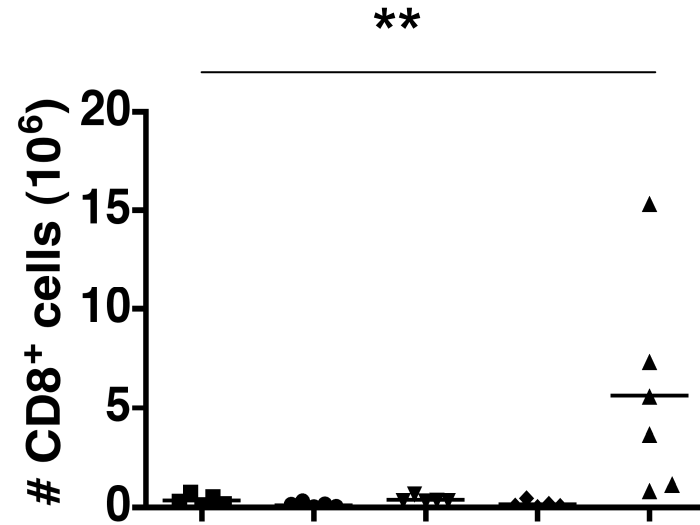
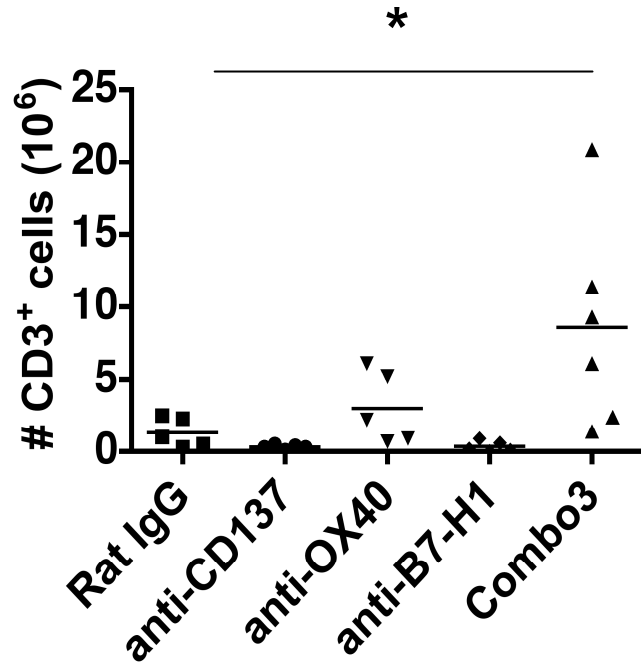

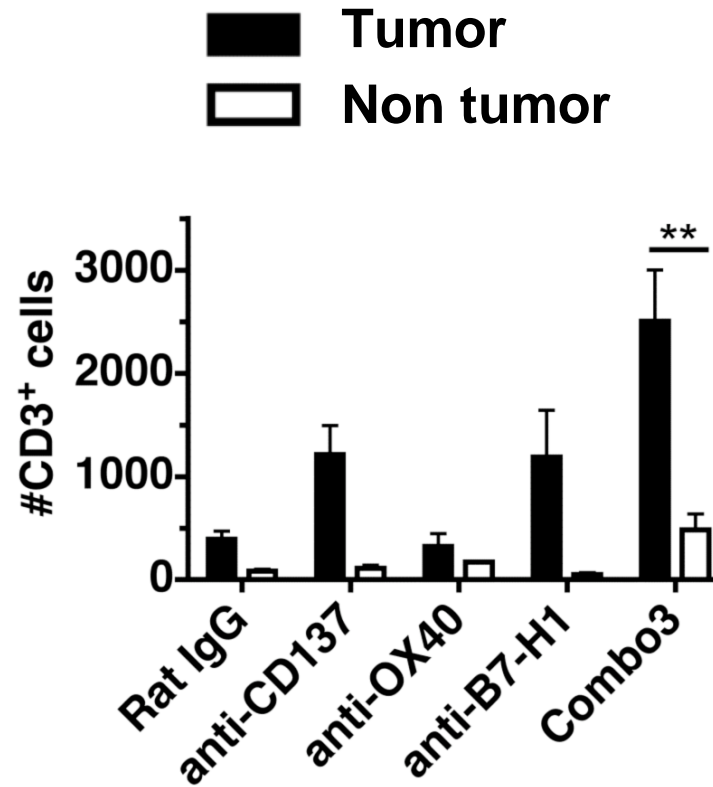
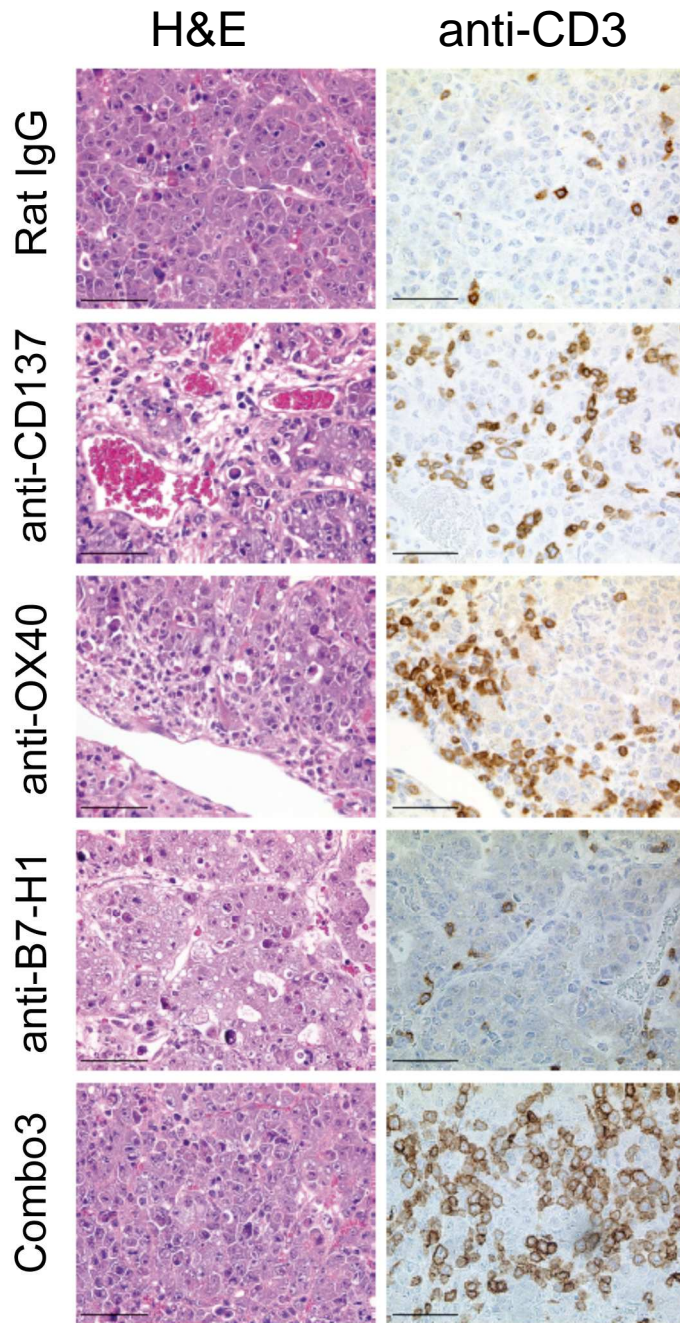

Combo3 efficacy is dependent on CD8⁺ T cells

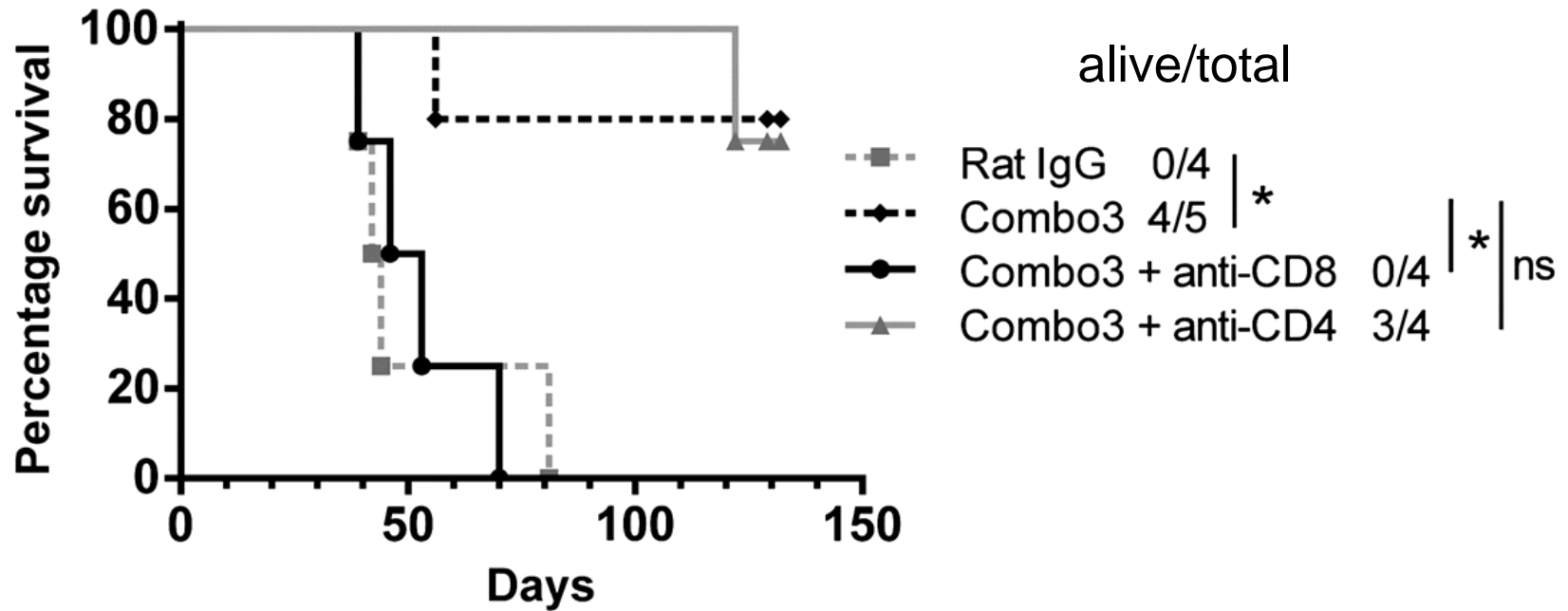

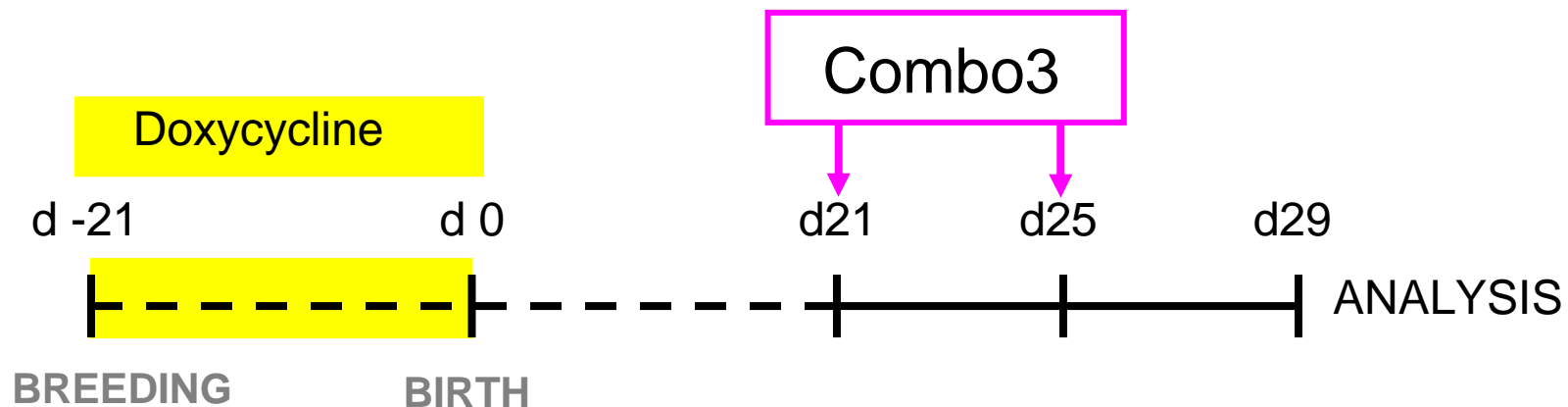

**CD8⁺
TILs**

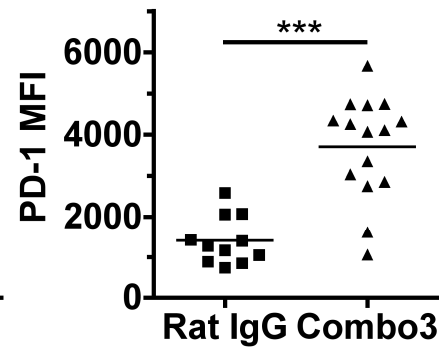
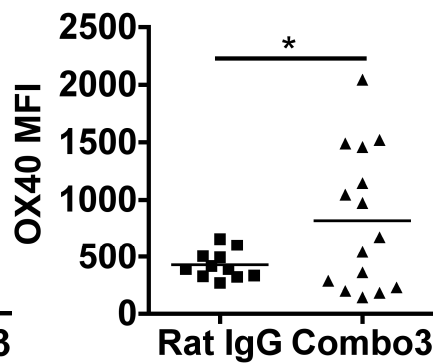
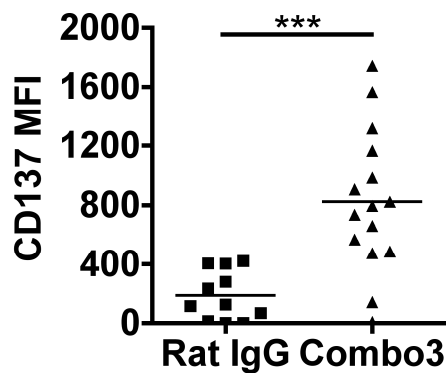
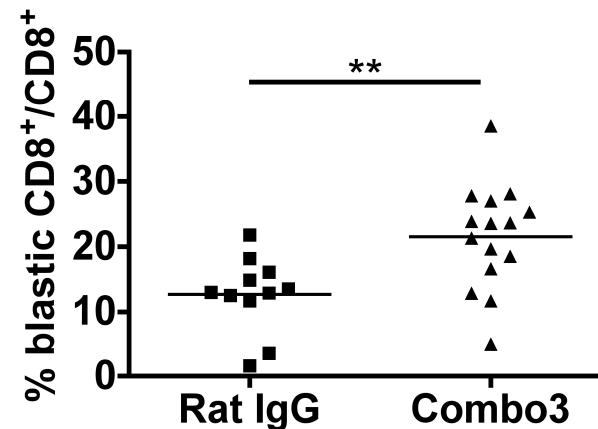
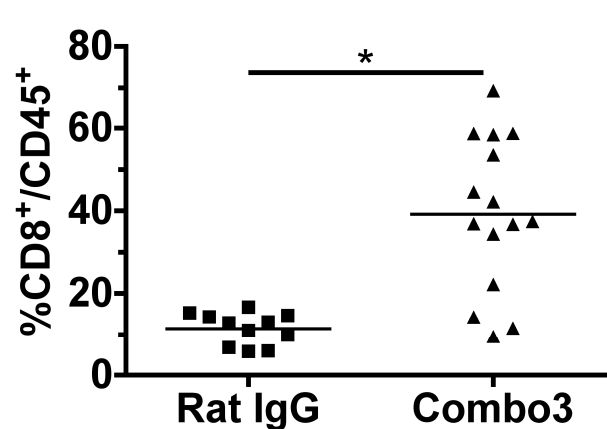

Effector machinery is enhanced upon Combo3 Tx

Gated on CD8 TILs

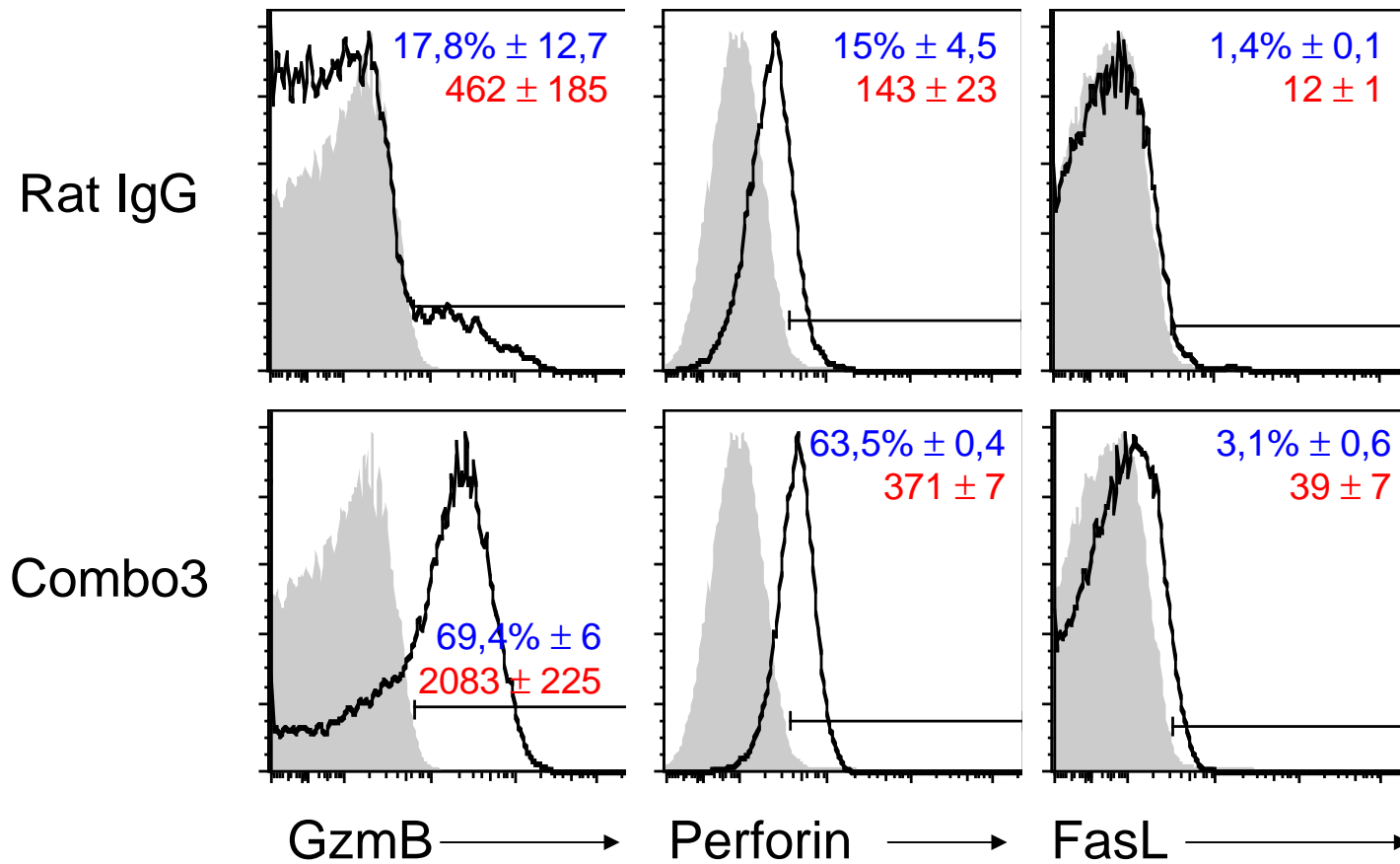

C-myc OVA tg+ mice are tolerized against SIINFEKL

JMJ cell line

HCC tumor fragments

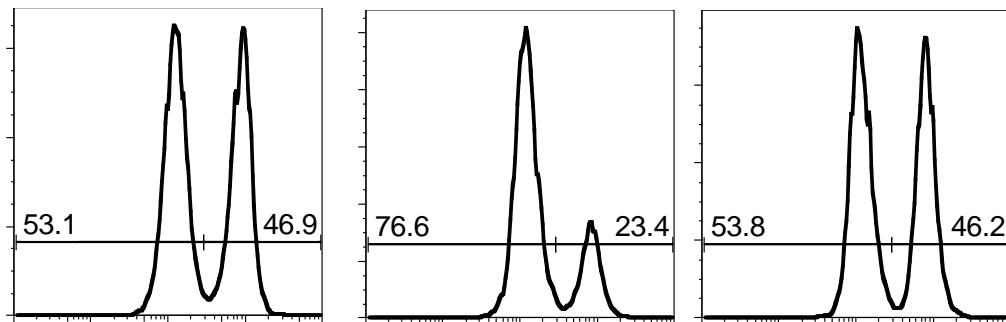
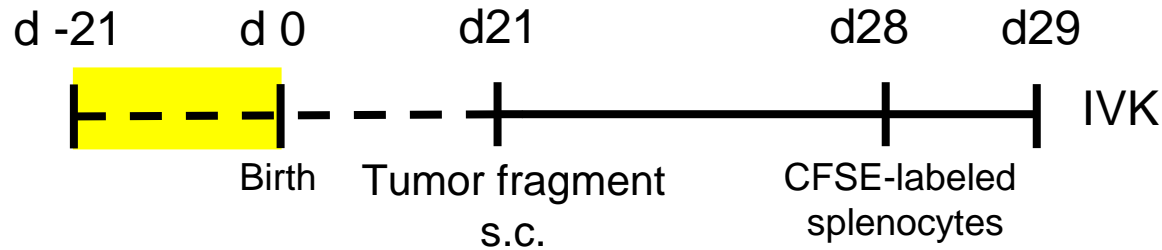
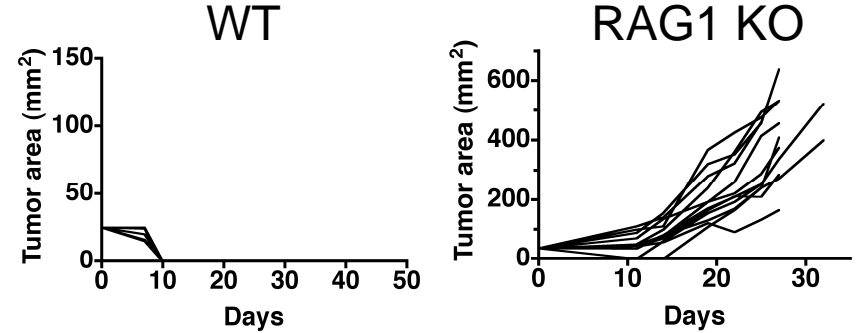
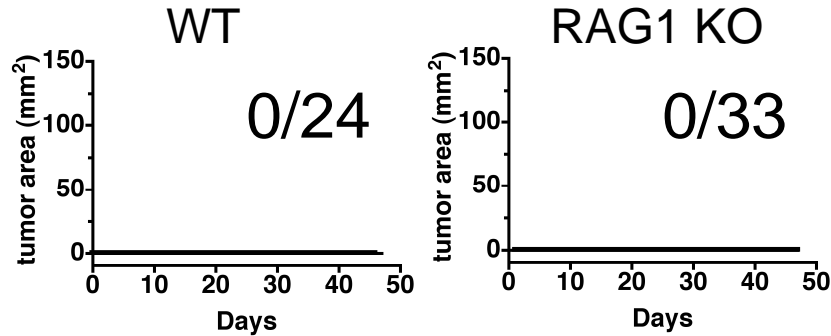

Naive WT

Immunized WT

C-myc OVA tg+ mice

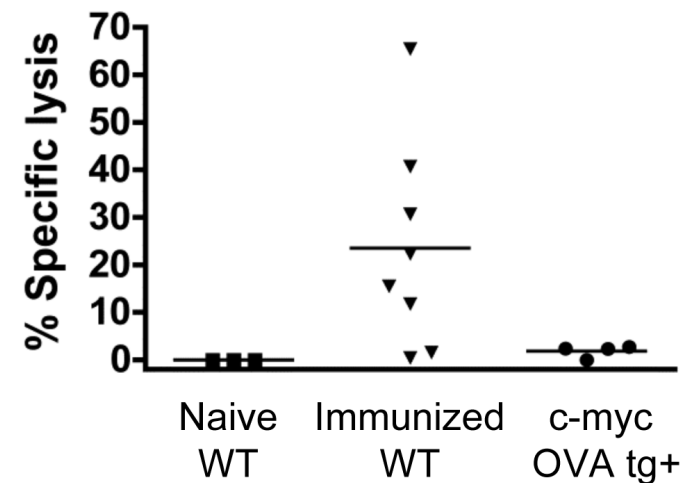

SIINFEKL does not drive Ag-specific T cell response

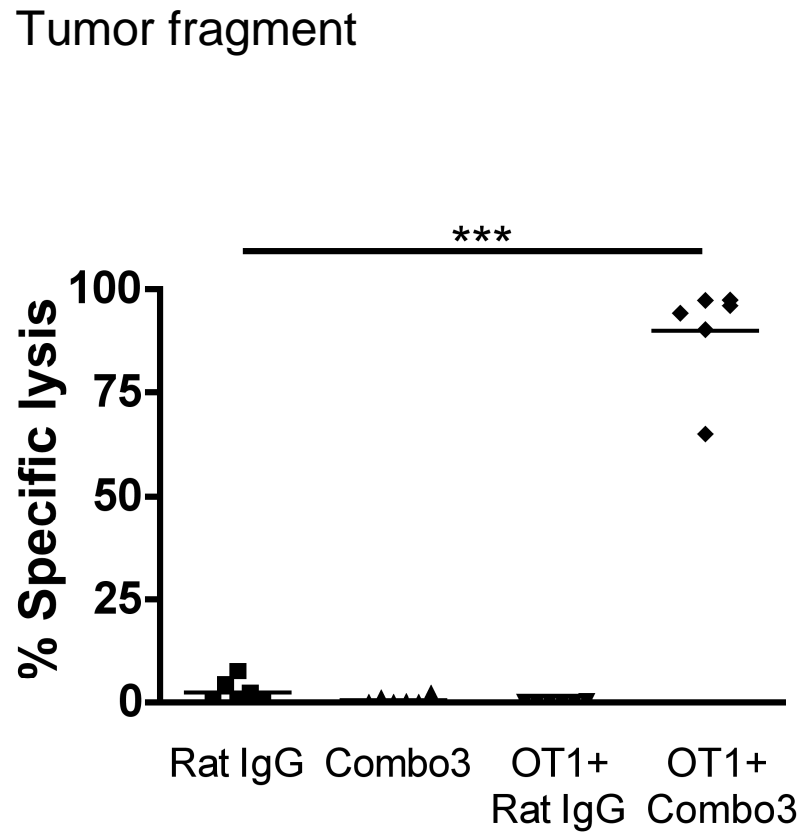
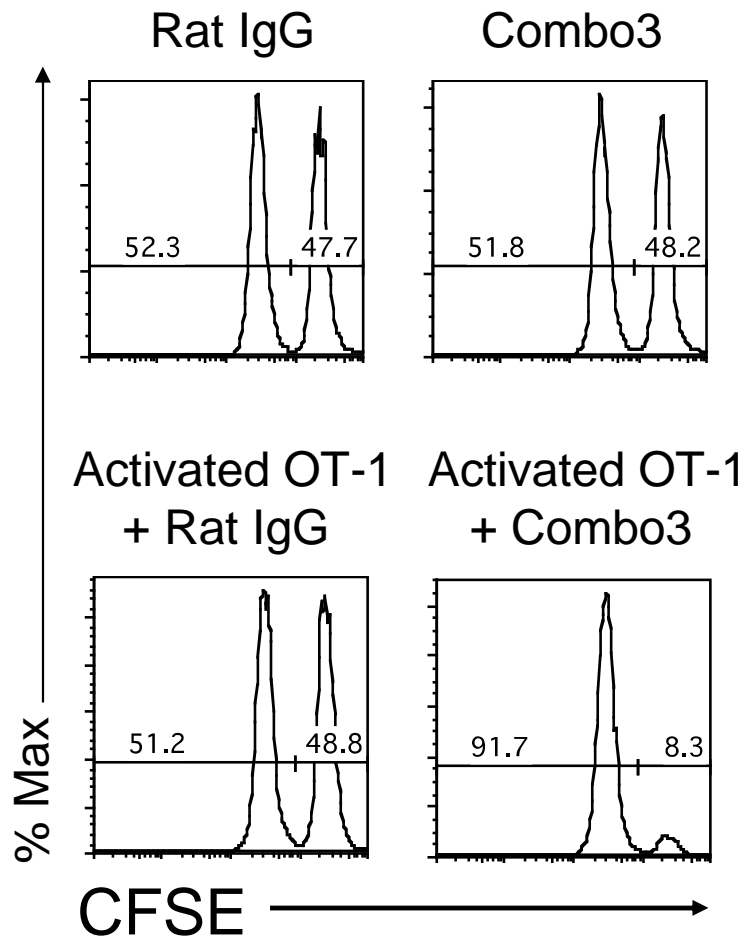
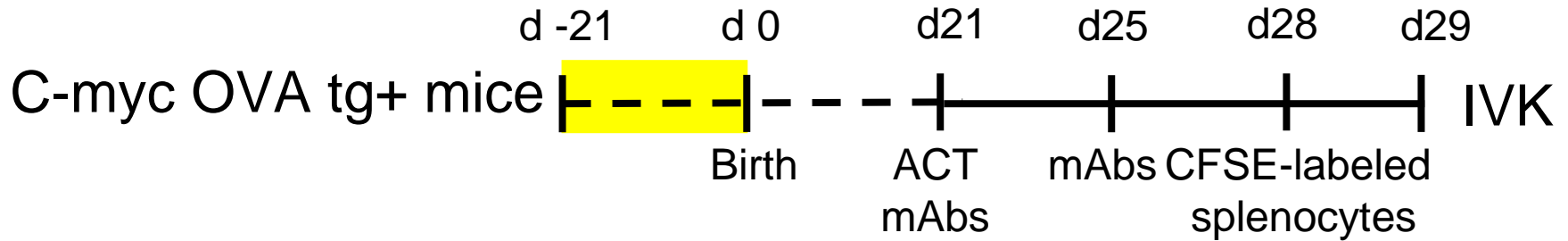

TILs recognize specific unknown peptides presented by JMJ cell line and secrete IFN γ

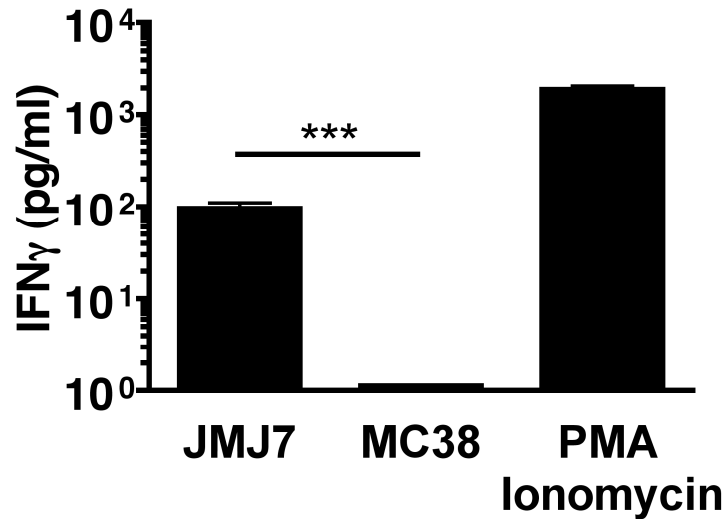

H-2K^b and D^b binding
feasible epitopes
(Immune Epitope Database)

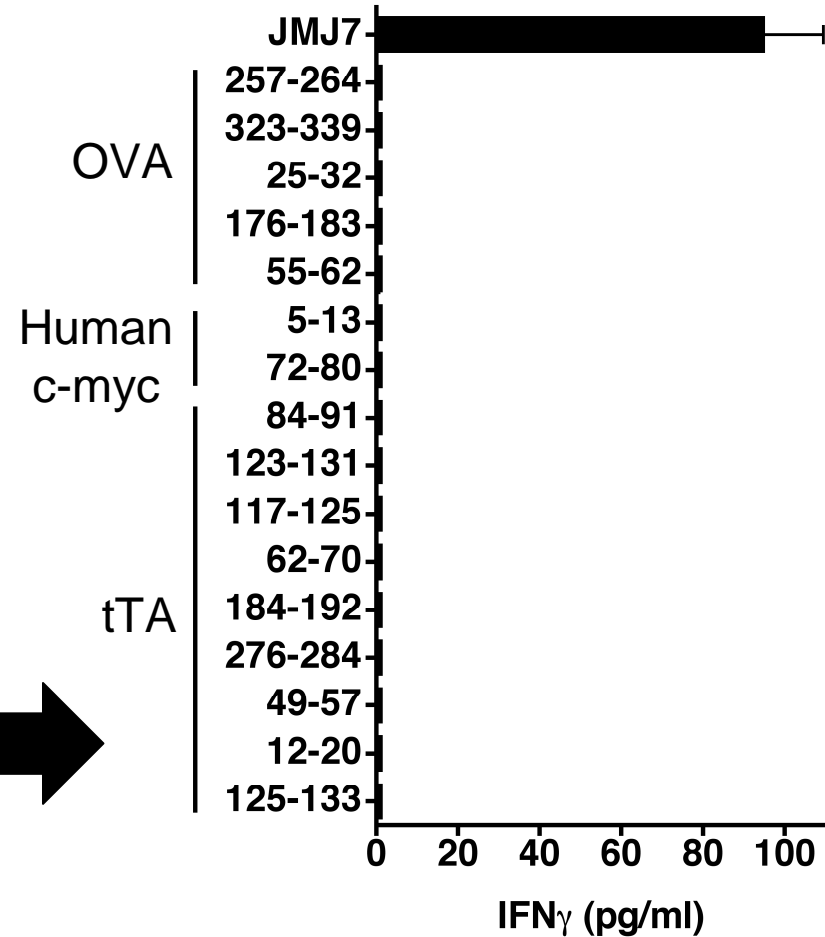
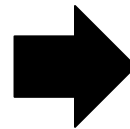

CONCLUSIONS

- Combo3 prolongs the survival of c-myc OVA tg+ mice and synergizes with adoptive T cell therapy of activated OT-1 and OT-2 T cells, in a CD8⁺ T lymphocyte dependent fashion
- Combo3 increases CD3⁺ lymphocyte infiltrates in tumor nodules, but not healthy liver tissue
- CD8⁺ TILs are more blastic and show higher expression of Combo3 targets, allowing the readministration of Combo3
- Combo3 prevents the tolerization of transferred activated OT-1 T cells against SIINFEKL
- TILs from Combo3 treated mice recognize unknown epitopes on HCC-derived cell lines, but not SIINFEKL

AKNOWLEDGEMENTS

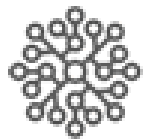

cima

CENTRO DE INVESTIGACIÓN MÉDICA APLICADA
UNIVERSIDAD DE NAVARRA

Nacho Melero
Ines Gutgemann
Miguel F. Sanmamed
Inma Rodríguez
Asís Palazón
Iván Martínez-Forero
José Medina
Sara Labiano



Red Temática de
Investigación Cooperativa
en Cáncer



"Una manera de hacer Europa"

Thanks for your attention
Questions?

LOOKING FOR POST-DOC!!

amoralesc@unav.es

